

New Door Preparation

Model No. RF-01

Mark Door

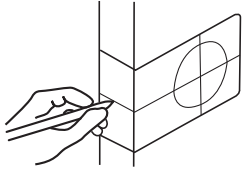

A. Use template provided to mark door for drilling 43" (110cm) from the base of the door or 8" above door knob or lever, center to center.

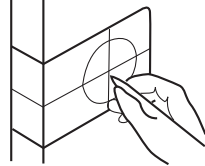

B. Use the template to select backset 2 3/8" (60mm) or 2-3/4" (70mm).

Drilling

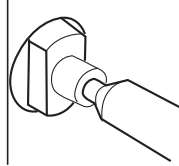

A. Bore 2-1/8" (54mm) hole through door face from both sides of door to avoid damaging door surface.

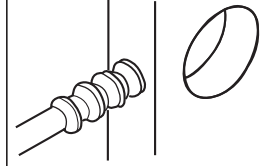

B. Drill 24mm (15/16") to 25mm (1") hole through door edge.

Install Deadbolt

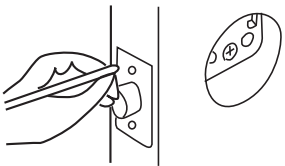

A. Insert deadbolt latch into hole. Mark all around the plate and the screw holes.

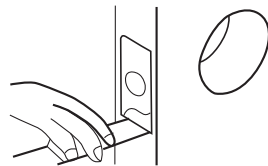

B. Drill 1/16" pilot holes for screws. Chisel recess for face plate.

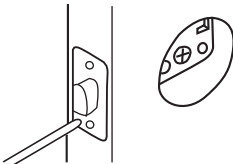

C. Secure latch with screws.

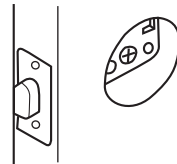

D. Make sure the face plate of the latch is flush with edge of door.

Install Door Jamb

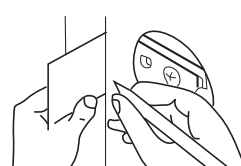

A. Shut door and mark door jamb exactly opposite center of bolt hole by tracing hole.

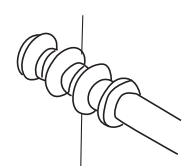

B. Drill an enlarge hole jamb 1" (25mm) and 1" (25mm) deep.

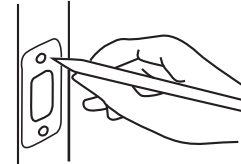

C. Mark all around plate and chisel recess at least 1/10" (2.5mm) for strike box.

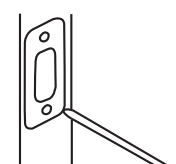

D. Secure strike plate with screws

Deadbolt Latch Must Be Able To Operate Smoothly With Door Jamb, Strike Box, And Strike Plate, After Installation.

TEMPLATE

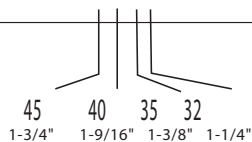

Mark 24mm (15/16") hole at center of door edge.

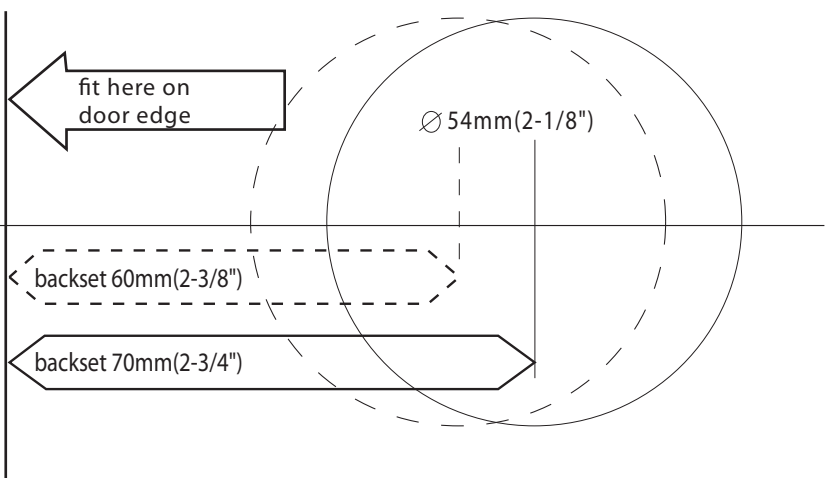

Security Hardware:
Touchpad, Infrared Remote,
Mechanical Door Locks

www.ca-tec.com

We make your life easy and safe

Tel. 604.451.5398 Fax. 604.677.5544