

**CODELOCK
5000
ELECTRONIC**



Check the contents of the box as below:

Box Contents

- 1** Front Plate
 - 2** Lever handles x 2
 - 3** Back Plate
 - 4** Gaskets x 2
 - 5** Spindle
 - 6** Mortice latch, strike & 4 screws
 - 7** 1.5v AA batteries x 4
 - 8** Philips head through fixing bolts x 4 (1 spare)
 - 9** Cable tube with fixing ring
 - 10** Alignment insert
 - 11** Latch support post
 - 12** Allen keys x 2
 - 13** Cylinder keys x 2
 - 14** 2 x cable connections for REM 1 and REM 2
- Installation template
 - Programming Guide

Tools Required

- Power Drill
- Drill bits 10mm, 25mm.
- Philips screwdriver
- Hammer / mallet
- Chisel 25mm
- Stanley knife
- Adhesive tape, pencil, bradawl, tape measure
- Pliers and hacksaw for cutting bolts

CONTENTS

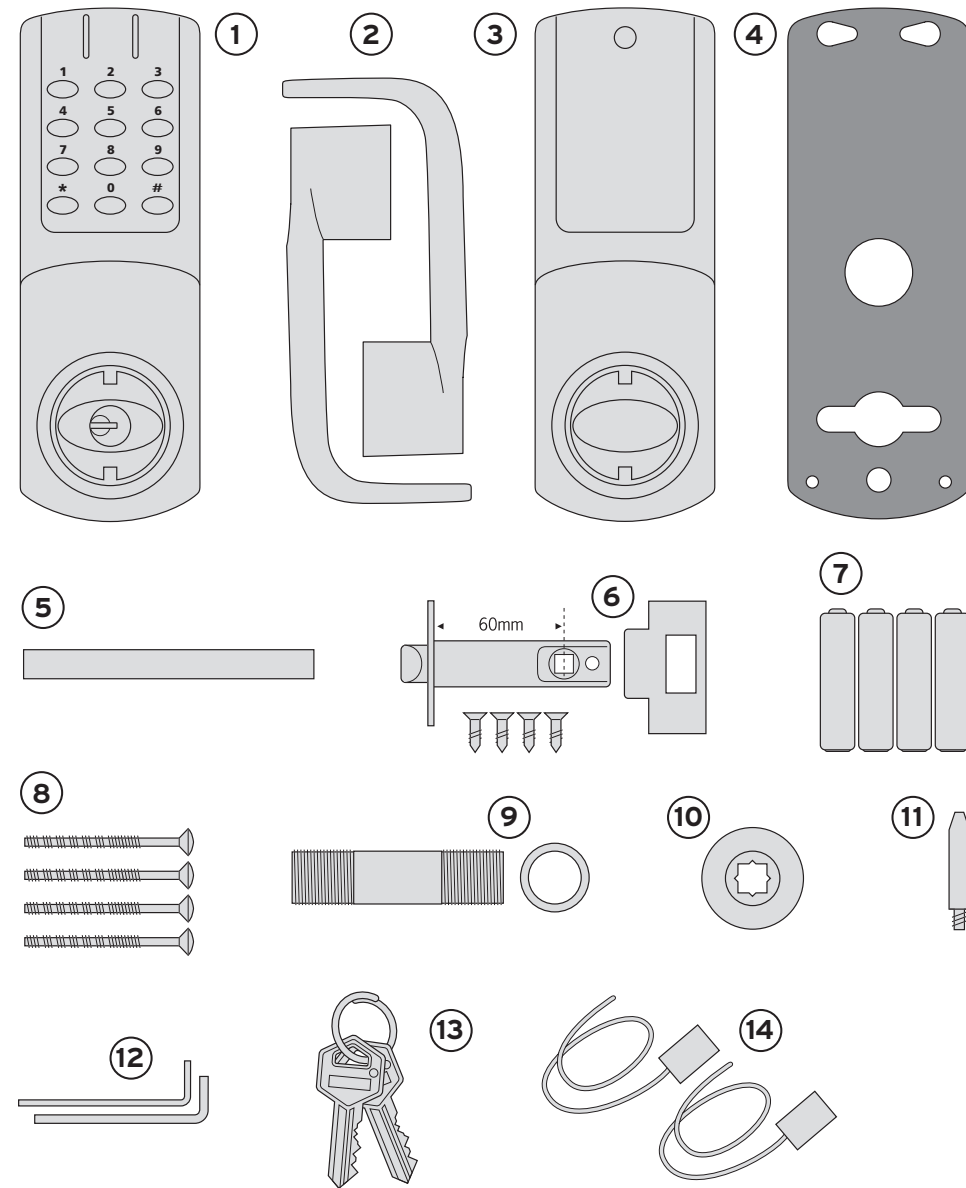

OPERATIONS CHECK

After checking that the contents are as shown on the previous page, you should familiarise yourself with the operation of the lock and check that all parts are working correctly.

- Remove the battery cover from the backplate with the Allen key and install the 4 x AA cells supplied.
- Lay the front and backplate on their side on a bench, connecting via their mating cables. Fix the spindle to the inside of the frontplate and then the backplate.
- Place a lever handle over the boss of the front plate, securing the grub screw underneath.
- Enter the master code #1234. The blue LED should burn and turning the lever handle will turn the spindle.
- Put the lock into Code Free Mode using the key so that the lever will turn the spindle without using the code. Leave the lock in the Code Free Mode.
- Disconnect the cables, but leave the lever handle and spindle attached to the front plate.
- Check that the latchbolt moves freely when pressed in. Check that the latchbolt retracts when the spindle is inserted through the follower and turned. Press and hold in the plunger beside the main bolt and confirm that the main bolt cannot now be pushed in; ie. it is deadlocked. This feature prevents the latchbolt being easily manipulated to open a locked door.

SPECIAL FIXING NOTE

REMOTE RELEASE OPTION

The lock has 2 sets of terminals for remote release, labelled REM 1 and REM 2 on the printed circuit board in the front housing. Cables are provided with the lock for these connections.

REM 1 is intended for use where there is a need to allow a visitor to open the door after having been identified by intercom or by sight from within. REM 1 would be connected to a pushbutton on a reception desk, or to the appropriate button on an intercom. Pushing the button would cause the Blue LED to light and would release the lock for the normal set time.

REM 2 is intended for use where there is a need for the door to be released by an alarm system, such as a fire alarm. This enables emergency personnel to rapidly check that no one is trapped/overlooked in classrooms, wards, guest rooms, etc during an emergency evacuation, or during a fire drill. When activated by an alarm REM 2 will maintain the unlocked condition for 30 minutes. During this time the red LED will flash once every second and sound an audible alarm to indicate the unlocked condition. The lock will automatically revert to normal after 30 minutes. If required Program 11 can be used to revert the lock to normal before the 30 minute period has finished.

INSTALLATION

All door locks should be installed with a degree of precision to ensure that all components are vertically and horizontally accurate in relation to each other, and in relation to the door.

Step 1

Lightly mark a height line on the edge and both faces of the door and on the door jam, to indicate the top of the lock when fitted.

Crease the template along one of the dotted lines (60mm or 70mm latch) and tape it to the door with the top in line with the height line. Mark the 5 x 10mm holes and 2 x 25mm holes.

Mark the centre of the door edge on the Centre Line of Latch. Remove the template and apply it to the other side of the door, aligning it accurately with the height line and the first centre line of latch mark. Mark the holes again. (See diagram A).

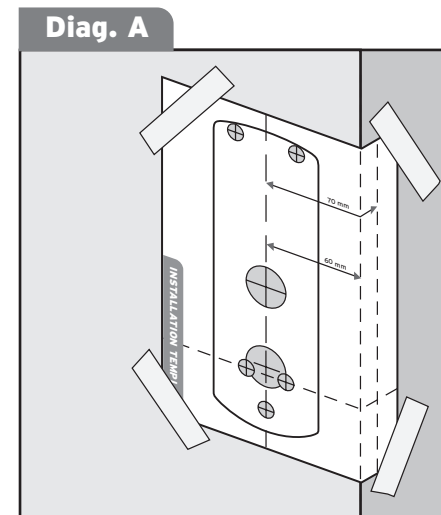

Step 2

Keeping the drill level and square, drill a 25mm hole on the centre of the door edge to accept the latch.

Step 3

Keeping the drill level and square, drill the five 10 mm holes and two 25mm holes. Drill from both sides of the door to increase accuracy and to avoid splintering of the door face.

Step 4

Put the latch into the hole and, holding it square to the door edge, draw around the faceplate. Remove the latch and score the outline with a Stanley knife to avoid splitting when chiselling. Chisel a rebate allowing the latch to fit flush to the surface. (See diagram B).

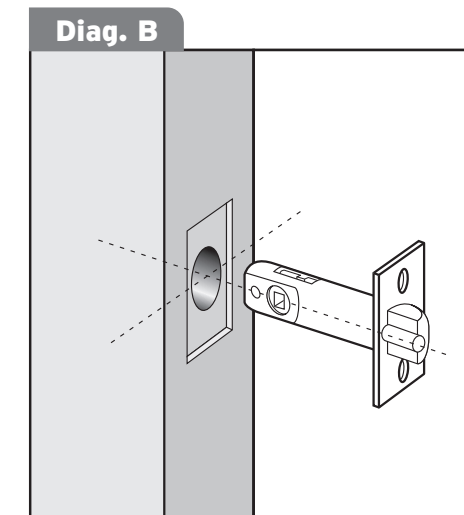

Step 5

Fix the latch with the wood screws, with the bevel towards the doorframe.

Step 6

Fit the latch support post on the inside of the front plate, in hole A for a right hand hung door and hole B for a left hand hung door. (See diagram C).

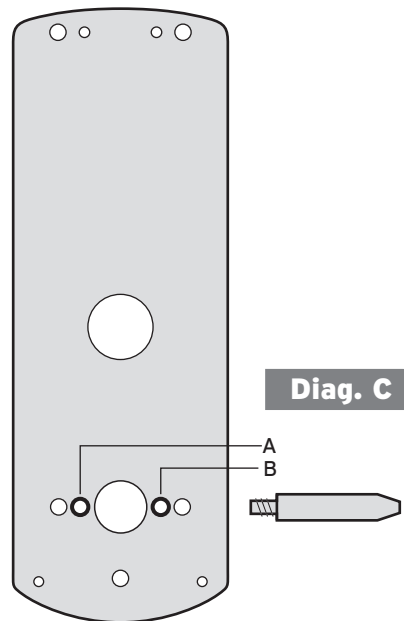

Step 7

Now take the cable tube. For doors between 35mm and 45mm thick screw the tube all the way into the outside plate. Before fitting the cable tube, pass through the cable connections. For doors thicker than 45mm do not screw the tube all the way into the outside plate but leave an appropriate amount of thread showing; eg. for a 60mm thick door leave at least 15mm of thread showing.

Step 8

Fit gaskets to front plate and the back plate

Step 9

Remove the 4 socket head bolts from the backplate (2 are found under the battery cover). This will release the inside fixing plate.

Step 10

Apply the front plate to the door, passing the spindle and cable tube through the door and locating the latch support post into the latch. From the inside of the door, place the fixing plate over the cable tube and spindle. Secure the fixing plate to the door with the ring nut.

Step 11

Cut the three (3) Philips head bolts to the required length. Approximate overall length should be the door thickness plus 10mm. Fix the bolts through the fixing plate and door into the front plate. Fit the alignment insert. (See diagram D).

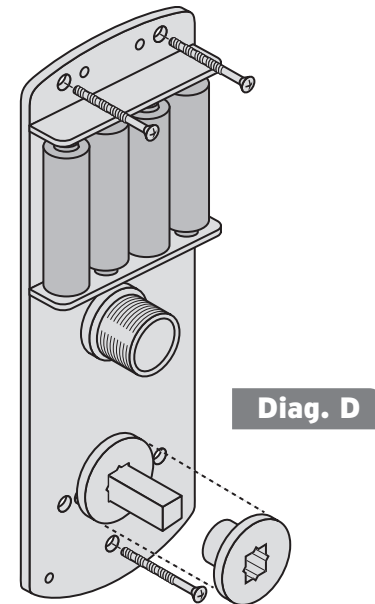

Step 12

Using the lever handle check that the spindle turns freely with the alignment insert in place. If required, loosen the fixing bolts and adjust the position of the fixing plate until the lever handle, latch and insert are all moving freely. Tighten the fixing bolts and remove the alignment insert.

Step 13

Connect the mating cables from the front plate and the battery pack. Fit the back plate over the spindle and secure it once again to the fixing plate with the 4 short socket head bolts. Replace the battery cover.

Fit the inner handle and secure it with the small grub screw.

Turn the key anticlockwise in the cylinder and back to the horizontal. The lever will now not retract the latch without first entering a valid code.

Step 14

Fitting the strike plate

Position the strike plate on the doorframe so that it lines up with the flat of the latchbolt, and NOT the plunger.

Mark the positions of the fixing screws and draw around the aperture of the strike plate.

Chisel out the aperture to 15mm deep to receive the latchbolt. Fix the strike plate to the surface of the frame using only the top fixing screw.

Gently close the door and check that the latchbolt enters the aperture easily, and is held without too much 'play'.

When satisfied, draw around the outline of the strike plate, remove it and cut a rebate to enable the faceplate to lie flush with the surface.

Re-fix the strike plate using both screws.

NB. The plunger beside the latchbolt deadlocks it to protect against manipulation or 'shimming'. The strike plate must be accurately installed so that the plunger CANNOT enter the aperture when the door is closed, even when it is slammed shut.